

Overview of the protocol

IMPORTANT

This is an Early Access product

For more information about our Early Access programmes, please see [this article on product release phases](#)

Please ensure you always use the most recent version of the protocol.

Native Barcoding Kit 24 V14 features

This kit is recommended for users who:

- want to obtain duplex data
- want to achieve median raw read accuracy of Q20+ (99%) and above
- want to optimise their sequencing experiment for accuracy and output
- wish to multiplex up to 24 samples to reduce price per sample
- need a PCR-free method of multiplexing to preserve additional information such as base modifications
- require control over read length
- would like to utilise upstream processes such as size selection or whole genome amplification

IMPORTANT

Kit 14 sequencing and duplex basecalling info sheet

The Kit 14 chemistry is a new development from Oxford Nanopore Technologies with improved duplex basecalling, which requires a different set of tools. For more information, please see the [Kit 14 sequencing and duplex basecalling info sheet](#). We strongly recommend that you read it before proceeding with Kit 14 chemistry sequencing experiments and basecalling duplex data.

Introduction to the Native Barcoding Kit 24 V14 protocol

This protocol describes how to carry out native barcoding of genomic DNA (gDNA) using the Native Barcoding Kit 24 V14 (SQK-NBD114.24). There are 24 unique barcodes available, allowing the user to pool up to 24 different samples in one sequencing experiment. It is highly recommended that a Lambda control experiment is completed first to become familiar with the technology.

Steps in the sequencing workflow:

Prepare for your experiment

You will need to:

- Extract your DNA, and check its length, quantity and purity. **The quality checks performed during the protocol are essential in ensuring experimental success.**
- Ensure you have your sequencing kit, the correct equipment and third-party reagents
- Download the software for acquiring and analysing your data

- Check your flow cell to ensure it has enough pores for a good sequencing run

Prepare your library

You will need to:

- Repair the DNA, and prepare the DNA ends for adapter attachment
- Ligate Native barcodes supplied in the kit to the DNA ends
- Ligate sequencing adapters supplied in the kit to the DNA ends
- Prime the flow cell, and load your DNA library into the flow cell

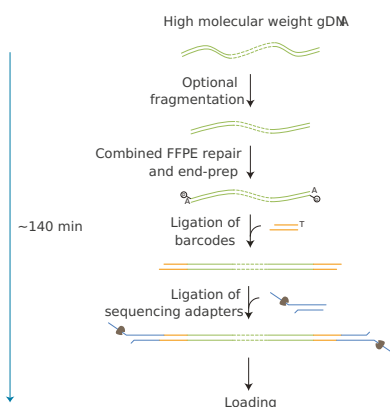

Sequencing

You will need to:

- Start a sequencing run using the MinKNOW software, which will collect raw data from the device and convert it into basecalled reads
- Demultiplex barcoded reads in MinKNOW or the Guppy basecalling, choosing the SQK-NBD114.24 kit option
- Start the EPI2ME software and select a workflow for further analysis (this step is optional)

IMPORTANT

We do not recommend mixing barcoded libraries with non-barcoded libraries prior to sequencing.

IMPORTANT

Optional fragmentation and size selection

By default, the protocol contains no DNA fragmentation step, however in some cases it may be advantageous to fragment your sample. For example, when working with lower amounts of input gDNA (100 ng – 500 ng), fragmentation will increase the number of DNA molecules and therefore increase throughput. Instructions are available in the [DNA Fragmentation section](#) of Extraction methods.

Additionally, we offer several options for size-selecting your DNA sample to enrich for long fragments - instructions are available in the [Size Selection section](#) of Extraction methods.

IMPORTANT

Compatibility of this protocol

This protocol should only be used in combination with:

- Native Barcoding Kit 24 V14 (SQK-NBD114.24)
- R10.4.1 flow cells (FLO-MIN114)
- Flow Cell Wash Kit (EXP-WSH004)
- Sequencing Auxiliary Vials V14 (EXP-AUX003)
- Native Barcoding Expansion V14 (EXP-NBA114)

Equipment and consumables

Materials

- Native Barcoding Kit 24 V14 (SQK-NBD114.24)
- 400 ng gDNA per sample if using >4 barcodes
- OR 1000 ng gDNA per sample if using ≤ 4 barcodes

Consumables

- NEB Blunt/TA Ligase Master Mix (NEB, cat # M0367)
- NEBNext FFPE Repair Mix (NEB, M6630)
- NEBNext Ultra II End repair/dA-tailing Module (NEB, cat # E7546)
- NEBNext Quick Ligation Module (NEB, cat # E6056)
- Eppendorf twin.tec® PCR plate 96 LoBind, semi-skirted (Eppendorf™, cat # 0030129504) with heat seals
- 1.5 ml Eppendorf DNA LoBind tubes
- 2 ml Eppendorf DNA LoBind tubes
- Nuclease-free water (e.g. ThermoFisher, AM9937)
- Freshly prepared 80% ethanol in nuclease-free water
- Qubit™ Assay Tubes (Invitrogen, Q32856)
- Qubit dsDNA HS Assay Kit (ThermoFisher, cat # Q32851)
- (Optional) Bovine Serum Albumin (BSA) (50 mg/ml) (e.g. Invitrogen™ UltraPure™ BSA 50 mg/ml, AM2616)

Equipment

- Hula mixer (gentle rotator mixer)
- Microplate centrifuge, e.g. Fisherbrand™ Mini Plate Spinner Centrifuge (Fisher Scientific, cat # 11766427)
- Microfuge
- Magnetic rack
- Vortex mixer
- Thermal cycler
- Multichannel pipette
- P1000 pipette and tips
- P200 pipette and tips

- P100 pipette and tips
- P20 pipette and tips
- P10 pipette and tips
- P2 pipette and tips
- Ice bucket with ice
- Timer
- Eppendorf 5424 centrifuge (or equivalent)
- Qubit fluorometer (or equivalent for QC check)

Optional Equipment

- Nanodrop spectrophotometer

For this protocol, we recommend the following inputs:

- 400 ng per sample for >4 barcodes
- 1000 ng per sample for ≤4 barcodes

Input DNA

How to QC your input DNA

It is important that the input DNA meets the quantity and quality requirements. Using too little or too much DNA, or DNA of poor quality (e.g. highly fragmented or containing RNA or chemical contaminants) can affect your library preparation.

For instructions on how to perform quality control of your DNA sample, please read the [input DNA/RNA QC protocol](#).

Chemical contaminants

Depending on how the DNA is extracted from the raw sample, certain chemical contaminants may remain in the purified DNA, which can affect library preparation efficiency and sequencing quality. Read more about contaminants on the [Contaminants page](#) of the Community.

Third-party reagents

We have validated and recommend the use of all the third-party reagents used in this protocol. Alternatives have not been tested by Oxford Nanopore Technologies.

For all third-party reagents, we recommend following the manufacturer's instructions to prepare the reagents for use.

IMPORTANT

The Native Adapter (NA) used in this kit and protocol is not interchangeable with other sequencing adapters.

Native Barcoding Kit 24 V14 (SQK-NBD114.24) contents

Note: We are in the process of reformatting our kits with single-use tubes into a bottle format and reducing the concentration of EDTA.

Single-use tubes format with higher EDTA concentration:



NA :Native Adapter
 SB :Sequencing Buffer
 LIB :Library Beads
 LIS :Library Solution
 EB :Elution Buffer
 AXP :AMPure XP Beads
 LFB :Long Fragment Buffer
 SFB :Short Fragment Buffer
 FCF :Flow Cell Flush
 FCT :Flow Cell Tether
 EDTA :EDTA
 DCS :DNAControl Sample
 NB01 :Native Barcode 1
 NB02 :Native Barcode 2
 NB03 :Native Barcode 3
 NB04 :Native Barcode 4
 NB05 :Native Barcode 5
 NB06 :Native Barcode 6
 NB07 :Native Barcode 7
 NB08 :Native Barcode 8
 NB09 :Native Barcode 9
 NB10 :Native Barcode 10
 NB11 :Native Barcode 11
 NB12 :Native Barcode 12
 NB13 :Native Barcode 13
 NB14 :Native Barcode 14
 NB15 :Native Barcode 15
 NB16 :Native Barcode 16
 NB17 :Native Barcode 17
 NB18 :Native Barcode 18
 NB19 :Native Barcode 19
 NB20 :Native Barcode 20
 NB21 :Native Barcode 21
 NB22 :Native Barcode 22
 NB23 :Native Barcode 23
 NB24 :Native Barcode 24

Name	Acronym	Cap colour	No. of vials	Fill volume per vial (µl)
Native Barcodes	NB01-24	Clear	24 (one per barcode)	20
DNA Control Sample	DCS	Yellow	2	35
Native Adapter	NA	Green	1	40
Sequencing Buffer	SB	Red	1	700
Library Beads	LIB	Pink	1	600
Library Solution	LIS	White cap, pink label	1	600
Elution Buffer	EB	Black	1	500
AMPure XP Beads	AXP	Amber	4	1,200
Long Fragment Buffer	LFB	Orange	1	1,800
Short Fragment Buffer	SFB	Clear	1	1,800
EDTA†	EDTA	Clear	1	700
Flow Cell Flush	FCF	Blue	6	1,170
Flow Cell Tether	FCT	Purple	1	200

† Higher concentration of EDTA with a clear cap.

Bottle format with reduced EDTA concentration:

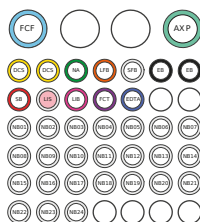

NA :Native Adapter
 SB :Sequencing Buffer
 LIB :Library Beads
 LIS :Library Solution
 EB :Elution Buffer
 AXP :AMPure XP Beads
 LFB :Long Fragment Buffer
 SFB :Short Fragment Buffer
 FCF :Flow Cell Flush
 FCT :Flow Cell Tether
 EDTA :EDTA
 DCS :DNAControl Sample
 NB01 :Native Barcode 1
 NB02 :Native Barcode 2
 NB03 :Native Barcode 3
 NB04 :Native Barcode 4
 NB05 :Native Barcode 5
 NB06 :Native Barcode 6
 NB07 :Native Barcode 7
 NB08 :Native Barcode 8
 NB09 :Native Barcode 9
 NB10 :Native Barcode 10
 NB11 :Native Barcode 11
 NB12 :Native Barcode 12
 NB13 :Native Barcode 13
 NB14 :Native Barcode 14
 NB15 :Native Barcode 15
 NB16 :Native Barcode 16
 NB17 :Native Barcode 17
 NB18 :Native Barcode 18
 NB19 :Native Barcode 19
 NB20 :Native Barcode 20
 NB21 :Native Barcode 21
 NB22 :Native Barcode 22
 NB23 :Native Barcode 23
 NB24 :Native Barcode 24

Name	Acronym	Cap colour	No. of vials	Fill volume per vial (µl)
Native Barcodes	NB01-24	Clear	24 (one per barcode)	20
DNA Control Sample	DCS	Yellow	2	35
Native Adapter	NA	Green	1	40
Sequencing Buffer	SB	Red	1	700
Library Beads	LIB	Pink	1	600
Library Solution	LIS	White cap, pink label	1	600
Elution Buffer	EB	Black	2	500
AMPure XP Beads	AXP	Light teal	1	6,000
Long Fragment Buffer	LFB	Orange	1	1,800
Short Fragment Buffer	SFB	Clear	1	1,800
EDTA‡	EDTA	Blue	1	700
Flow Cell Flush	FCF	Light blue	1	8,000
Flow Cell Tether	FCT	Purple	1	200

‡ Reduced concentration of EDTA with a blue cap.

Note: This Product Contains AMPure XP Reagent Manufactured by Beckman Coulter, Inc. and can be stored at -20°C with the kit without detriment to reagent stability.

To maximise the use of the Native Barcoding Kits, the Native Barcode Auxiliary V14 (EXP-NBA114) and the Sequencing Auxiliary Vials V14 (EXP-AUX003) expansion packs are available.

These expansions provide extra library preparation and flow cell priming reagents to allow users to utilise any unused barcodes for those running in smaller subsets.

Both expansion packs used together will provide enough reagents for 12 reactions. For customers requiring extra EDTA to maximise the use of barcodes, we recommend using 0.25 M EDTA and adding 4 µl for library preps of up to 24 barcodes and 2 µl for preps from 25 up to 96 barcodes.

Native Barcode Auxiliary V14 (EXP-NBA114) contents:

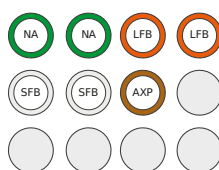

NA : NativeAdapter
LFB : Long Fragment Buffer
SFB : Short Fragment Buffer
AXP : AMPure XP Beads

Name	Acronym	Cap colour	No. of vials	Fill volume per vial (µl)
Native Adapter	NA	Green	2	40
AMPure XP Beads	AXP	Amber	1	400
Long Fragment Buffer	LFB	Orange	2	1,800
Short Fragment Buffer	SFB	Clear	2	1,800

Note: This Product contains AMPure XP Reagent manufactured by Beckman Coulter, Inc. and can be stored at -20°C with the kit without detriment to reagent stability.

Sequencing Auxiliary Vials V14 (EXP-AUX003) contents:

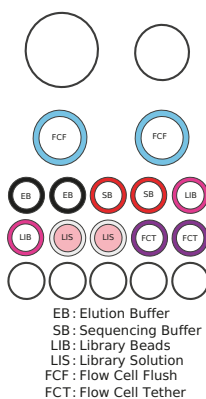

Name	Acronym	Cap colour	No. of vials	Fill volume per vial (µl)
Elution Buffer	EB	Black	2	500
Sequencing Buffer	SB	Red	2	700
Library Solution	LIS	White cap, pink label	2	600
Library Beads	LIB	Pink	2	600
Flow Cell Flush	FCF	light blue label	2	8,000
Flow Cell Tether	FCT	Purple	2	200

Native barcode sequences

Component	Forward sequence	Reverse sequence
NB01	CACAAAGACACCGACAACCTTTCTT	AAGAAAGTTGTCCGGTGTCTTTGTG
NB02	ACAGACGACTACAAACGGAATCGA	TCGATTCCGTTTGTAGTCGTCTGT
NB03	CCTGGTAACTGGGACACAAGACTC	GAGTCTTGTGTCCCAGTTACCAGG
NB04	TAGGGAAACACGATAGAATCCGAA	TTCGGATTCTATCGTGTTCCTA
NB05	AAGGTTACACAAACCCTGGACAAG	CTTGTCCAGGGTTTGTGTAACCTT
NB06	GACTACTTTCTGCCTTTGCGAGAA	TTCTCGCAAAGGCAGAAAGTAGTC
NB07	AAGGATTCATTCCCACGGTAACAC	GTGTTACCGTGGGAATGAATCCTT

Component	Forward sequence	Reverse sequence
NB08	ACGTAACCTGGTTTGTCCCTGAA	TTCAGGGAACAAACCAAGTTACGT
NB09	AACCAAGACTCGCTGTGCCTAGTT	AACTAGGCACAGCGAGTCTTGGTT
NB10	GAGAGGACAAAGGTTTCAACGCTT	AAGCGTTGAAACCTTTGTCCTCTC
NB11	TCCATTCCCTCCGATAGATGAAAC	GTTTCATCTATCGGAGGGAATGGA
NB12	TCCGATTCTGCTTCTTTCTACCTG	CAGGTAGAAAGAAGCAGAATCGGA
NB13	AGAACGACTTCCATACTCGTGTGA	TCACACGAGTATGGAAGTCGTTCT
NB14	AACGAGTCTCTTGGGACCCATAGA	TCTATGGGTCCCAAGAGACTCGTT
NB15	AGGTCTACCTCGCTAACACCACTG	CAGTGGTGTTAGCGAGGTAGACCT
NB16	CGTCAACTGACAGTGGTTCGTA	AGTACGAACCACTGTCAGTTGACG
NB17	ACCCTCCAGGAAAGTACCTCTGAT	ATCAGAGGTACTTTCTGGAGGGT
NB18	CCAAACCAACAACCTAGATAGGC	GCCTATCTAGGTTGTTGGGTTTGG
NB19	GTTCCCTCGTGCAGTGTCAAGAGAT	ATCTCTTGACACTGCACGAGGAAC
NB20	TTGCGTCTGTTACGAGAACTCAT	ATGAGTTCTCGTAACAGGACGCAA
NB21	GAGCCTCTCATTGTCCGTTCTCTA	TAGAGAACGGACAATGAGAGGCTC
NB22	ACCACTGCCATGTATCAAAGTACG	CGTACTTTGATACATGGCAGTGGT
NB23	CTTACTACCCAGTGAACCTCCTCG	CGAGGAGGTTCACTGGGTAGTAAG
NB24	GCATAGTTCTGCATGATGGGTTAG	CTAACCCATCATGCAGAACTATGC

Computer requirements and software

MinION Mk1C IT requirements

The MinION Mk1C contains fully-integrated compute and screen, removing the need for any accessories to generate and analyse nanopore data. Read more in the [MinION Mk1C IT requirements document](#)

MinION Mk1B IT requirements

Sequencing on a MinION Mk1B requires a high-spec computer or laptop to keep up with the rate of data acquisition. Read more in the [MinION IT Requirements document](#).

Software for nanopore sequencing

MinKNOW

The MinKNOW software controls the nanopore sequencing device, collects sequencing data and basecalls in real time. You will be using MinKNOW for every sequencing experiment to sequence, basecall and demultiplex if your samples were barcoded.

For instructions on how to run the MinKNOW software, please refer to the [MinKNOW protocol](#).

EPI2ME (optional)

The EPI2ME cloud-based platform performs further analysis of basecalled data, for example alignment to the Lambda genome, barcoding, or taxonomic classification. You will use the EPI2ME platform *only* if you would like further analysis of your data post-basecalling.

For instructions on how to create an EPI2ME account and install the EPI2ME Desktop Agent, please refer to the [EPI2ME Platform protocol](#).

Check your flow cell

We highly recommend that you check the number of pores in your flow cell prior to starting a sequencing experiment. This should be done within three months of purchasing for MinION/GridION/PromethION or within four weeks of purchasing Flongle Flow Cells. Oxford Nanopore Technologies will replace any flow cell with fewer than the number of pores in the table below, when the result is reported within two days of performing the flow cell check, and when the storage recommendations have been followed. To do the flow cell check, please follow the instructions in the [Flow Cell Check document](#).

Flow cell	Minimum number of active pores covered by warranty
Flongle Flow Cell	50
MinION/GridION Flow Cell	800
PromethION Flow Cell	5000

DNA repair and end-prep

~20 minutes

Materials

- 400 ng gDNA per barcode
- OR 1000 ng gDNA per sample if using ≤ 4 barcodes
- AMPure XP Beads (AXP)
- DNA Control Sample (DCS)

Consumables

- NEBNext FFPE DNA Repair Mix (NEB, cat # M6630)
- NEBNext® Ultra II End Repair / dA-tailing Module (NEB, cat # E7546)
- Freshly prepared 80% ethanol in nuclease-free water
- 1.5 ml Eppendorf DNA LoBind tubes
- Eppendorf twin.tec® PCR plate 96 LoBind, semi-skirted (Eppendorf™, cat # 0030129504) with heat seals
- OR 0.2 ml thin-walled PCR tubes
- Nuclease-free water (e.g. ThermoFisher, cat # AM9937)
- Qubit™ Assay Tubes (Invitrogen, Q32856)
- Qubit dsDNA HS Assay Kit (Invitrogen, Q32851)

Equipment

- P1000 pipette and tips
- P200 pipette and tips
- P100 pipette and tips
- P20 pipette and tips
- P10 pipette and tips
- P2 pipette and tips
- Multichannel pipette
- Thermal cycler
- Microplate centrifuge, e.g. Fisherbrand™ Mini Plate Spinner Centrifuge (Fisher Scientific, cat # 11766427)
- Microfuge
- Ice bucket with ice
- Magnetic rack
- Vortex mixer
- Hula mixer (rotator mixer)
- Qubit fluorometer (or equivalent)

TIP

For samples containing long gDNA fragments, we recommend using wide-bore pipette tips for the mixing steps to preserve the DNA length.

- 1 Thaw the AMPure XP Beads (AXP) and DNA Control Sample (DCS) at room temperature and mix by vortexing. Keep the beads at room temperature and store the DNA Control Sample (DCS) on ice.
- 2 Prepare the NEBNext FFPE DNA Repair Mix and NEBNext Ultra II End Repair / dA-tailing Module reagents in accordance with manufacturer's instructions, and place on ice.

For optimal performance, NEB recommend the following:

1. Thaw all reagents on ice.
2. Flick and/or invert the reagent tubes to ensure they are well mixed.

Note: Do not vortex the FFPE DNA Repair Mix or Ultra II End Prep Enzyme Mix.

3. Always spin down tubes before opening for the first time each day.
4. The Ultra II End Prep Buffer and FFPE DNA Repair Buffer may have a little precipitate. Allow the mixture to come to room temperature and pipette the buffer up and down several times to break up the precipitate, followed by vortexing the tube for 30 seconds to solubilise any precipitate.

Note: It is important the buffers are mixed well by vortexing.

5. The FFPE DNA Repair Buffer may have a yellow tinge and is fine to use if yellow.

IMPORTANT

Do not vortex the NEBNext FFPE DNA Repair Mix or NEBNext Ultra II End Prep Enzyme Mix.

IMPORTANT

It is important that the NEBNext FFPE DNA Repair Buffer and NEBNext Ultra II End Prep Reaction Buffer are mixed well by vortexing.

Check for any visible precipitate; vortexing for at least 30 seconds may be required to solubilise any precipitate.

3 Dilute your DNA Control Sample (DCS) by adding 105 µl Elution Buffer (EB) directly to one DCS tube. Mix gently by pipetting and spin down.

One tube of diluted DNA Control Sample (DCS) is enough for 140 samples. Excess can be stored at -20°C in the freezer.

TIP

We recommend using the DNA Control Sample (DCS) in your library prep for troubleshooting purposes. However, you can omit this step and make up the extra 1 µl with your sample DNA.

4 In clean 0.2 ml thin-walled PCR tubes (or a clean 96-well plate), prepare your DNA samples:

- For >4 barcodes, aliquot 400 ng per sample
- For ≤4 barcodes, aliquot 1000 ng per sample

5 Make up each sample to 11 µl using nuclease-free water. Mix gently by pipetting and spin down.

6 Combine the following components per tube/well:

Between each addition, pipette mix 10 - 20 times.

Reagent	Volume
DNA sample	11 µl
Diluted DNA Control Sample (DCS)	1 µl
NEBNext FFPE DNA Repair Buffer	0.875 µl
Ultra II End-prep Reaction Buffer	0.875 µl
Ultra II End-prep Enzyme Mix	0.75 µl
NEBNext FFPE DNA Repair Mix	0.5 µl
Total	15 µl

TIP

We recommend making up a mastermix of the end-prep and DNA repair reagents for the total number of samples and adding 3 μ l to each well.

- 7 Ensure the components are thoroughly mixed by pipetting and spin down in a centrifuge.**
- 8 Using a thermal cycler, incubate at 20°C for 5 minutes and 65°C for 5 minutes.**
- 9 Transfer each sample into a clean 1.5 ml Eppendorf DNA LoBind tube.**
- 10 Resuspend the AMPure XP beads (AXP) by vortexing.**
- 11 Add 15 μ l of resuspended AMPure XP Beads (AXP) to each end-prep reaction and mix by flicking the tube.**
- 12 Incubate on a Hula mixer (rotator mixer) for 5 minutes at room temperature.**
- 13 Prepare sufficient fresh 80% ethanol in nuclease-free water for all of your samples. Allow enough for 400 μ l per sample, with some excess.**
- 14 Spin down the samples and pellet the beads on a magnet until the eluate is clear and colourless. Keep the tubes on the magnet and pipette off the supernatant.**
- 15 Keep the tube on the magnet and wash the beads with 200 μ l of freshly prepared 80% ethanol without disturbing the pellet. Remove the ethanol using a pipette and discard.**

If the pellet was disturbed, wait for beads to pellet again before removing the ethanol.
- 16 Repeat the previous step.**
- 17 Briefly spin down and place the tubes back on the magnet for the beads to pellet. Pipette off any residual ethanol. Allow to dry for 30 seconds, but do not dry the pellets to the point of cracking.**
- 18 Remove the tubes from the magnetic rack and resuspend the pellet in 10 μ l nuclease-free water. Spin down and incubate for 2 minutes at room temperature.**
- 19 Pellet the beads on a magnet until the eluate is clear and colourless.**
- 20 Remove and retain 10 μ l of eluate into a clean 1.5 ml Eppendorf DNA LoBind tube.**
 - Dispose of the pelleted beads

Quantify 1 μ l of each eluted sample using a Qubit fluorometer.

END OF STEP

Take forward an equimolar mass of each sample to be barcoded forward into the native barcode ligation step. However, you may store the samples at 4°C overnight.

Native barcode ligation

~60 minutes

Materials

- Native Barcodes (NB01-24)
- AMPure XP Beads (AXP)
- EDTA (EDTA)

Consumables

- NEB Blunt/TA Ligase Master Mix (NEB, cat # M0367)
- Freshly prepared 80% ethanol in nuclease-free water
- Nuclease-free water (e.g. ThermoFisher, AM9937)
- 1.5 ml Eppendorf DNA LoBind tubes
- Eppendorf twin.tec® PCR plate 96 LoBind, semi-skirted (Eppendorf™, cat # 0030129504) with heat seals
- OR 0.2 ml thin-walled PCR tubes
- Qubit™ Assay Tubes (Invitrogen, Q32856)
- Qubit dsDNA HS Assay Kit (ThermoFisher, cat # Q32851)

Equipment

- Magnetic rack
- Vortex mixer
- Hula mixer (gentle rotator mixer)
- Microfuge
- Thermal cycler
- Ice bucket with ice
- Multichannel pipette
- P1000 pipette and tips
- P200 pipette and tips
- P100 pipette and tips
- P20 pipette and tips
- P10 pipette and tips
- P2 pipette and tips
- Qubit fluorometer (or equivalent for QC check)

1 Prepare the NEB Blunt/TA Ligase Master Mix according to the manufacturer's instructions, and place on ice:

1. Thaw the reagents at room temperature.
2. Spin down the reagent tubes for 5 seconds.
3. Ensure the reagents are fully mixed by performing 10 full volume pipette mixes.

- 2 Thaw the EDTA at room temperature and mix by vortexing. Then spin down and place on ice.
- 3 Thaw the Native Barcodes (NB01-24) required for your number of samples at room temperature. Individually mix the barcodes by pipetting, spin down, and place them on ice.
- 4 Select a unique barcode for each sample to be run together on the same flow cell. Up to 24 samples can be barcoded and combined in one experiment.

Please note: Only use one barcode per sample.

- 5 In clean 0.2 ml PCR-tubes or a 96-well plate, add the reagents in the following order per well:

Between each addition, pipette mix 10 - 20 times.

Reagent	Volume
End-prepped DNA	7.5 μ l
Native Barcode (NB01-24)	2.5 μ l
Blunt/TA Ligase Master Mix	10 μ l
Total	20 μl

- 6 Thoroughly mix the reaction by gently pipetting and briefly spinning down.
- 7 Incubate for 20 minutes at room temperature.
- 8 Add the following volume of EDTA to each well and mix thoroughly by pipetting and spin down briefly.

Note: Ensure you follow the instructions for the cap colour of your EDTA tube.

EDTA cap colour	Volume per well
For clear cap EDTA	2 μ l
For blue cap EDTA	4 μ l

TIP

EDTA is added at this step to stop the reaction.

9 Pool all the barcoded samples in a 1.5 ml Eppendorf DNA LoBind tube.

Note: Ensure you follow the instructions for the cap colour of your EDTA tube.

	Volume per sample	For 6 samples	For 12 samples	For 24 samples
Total volume for preps using clear cap EDTA	22 µl	132 µl	264 µl	528 µl
Total volume for preps using blue cap EDTA	24 µl	144 µl	288 µl	576 µl

TIP

We recommend checking the base of your tubes/plate are all the same volume before pooling and after to ensure all the liquid has been taken forward.

10 Resuspend the AMPure XP Beads (AXP) by vortexing.

11 Add AMPure XP Beads (AXP) to the pooled reaction, and mix by pipetting for a 0.4X clean.

Note: Ensure you follow the instructions for the cap colour of your EDTA tube.

	Volume per sample	For 6 samples	For 12 samples	For 24 samples
Volume of AXP for preps using clear cap EDTA	9 µl	53 µl	106 µl	211 µl
Volume of AXP for preps using blue cap EDTA	10 µl	58 µl	115 µl	230 µl

12 Incubate on a Hula mixer (rotator mixer) for 10 minutes at room temperature.

13 Prepare 2 ml of fresh 80% ethanol in nuclease-free water.

14 Spin down the sample and pellet on a magnet for 5 minutes. Keep the tube on the magnetic rack until the eluate is clear and colourless, and pipette off the supernatant.

15 Keep the tube on the magnetic rack and wash the beads with 700 µl of freshly prepared 80% ethanol without disturbing the pellet. Remove the ethanol using a pipette and discard.

If the pellet was disturbed, wait for beads to pellet again before removing the ethanol.

16 Repeat the previous step.

17 Spin down and place the tube back on the magnetic rack. Pipette off any residual ethanol. Allow the pellet to dry for ~30 seconds, but do not dry the pellet to the point of cracking.

18 Remove the tube from the magnetic rack and resuspend the pellet in 35 µl nuclease-free water by gently flicking.

19 Incubate for 10 minutes at 37°C. Every 2 minutes, agitate the sample by gently flicking for 10 seconds to encourage DNA elution.

20 Pellet the beads on a magnetic rack until the eluate is clear and colourless.

21 Remove and retain 35 µl of eluate into a clean 1.5 ml Eppendorf DNA LoBind tube.

Quantify 1 µl of eluted sample using a Qubit fluorometer.

END OF STEP

Take forward the barcoded DNA library to the adapter ligation and clean-up step. However, you may store the sample at 4°C overnight.

Adapter ligation and clean-up

~50 minutes

Materials

- Long Fragment Buffer (LFB)
- Short Fragment Buffer (SFB)
- Elution Buffer (EB)
- Native Adapter (NA)
- AMPure XP Beads (AXP)

Consumables

- NEBNext® Quick Ligation Module (NEB, E6056)
- 1.5 ml Eppendorf DNA LoBind tubes
- Qubit™ Assay Tubes (Invitrogen, Q32856)
- Qubit dsDNA HS Assay Kit (ThermoFisher, cat # Q32851)

Equipment

- Microfuge
- Magnetic rack
- Vortex mixer
- Hula mixer (gentle rotator mixer)
- Thermal cycler
- P1000 pipette and tips
- P200 pipette and tips
- P100 pipette and tips
- P20 pipette and tips
- P10 pipette and tips
- Ice bucket with ice
- Qubit fluorometer (or equivalent for QC check)

IMPORTANT

The Native Adapter (NA) used in this kit and protocol is not interchangeable with other sequencing adapters.

1 Prepare the NEBNext Quick Ligation Reaction Module according to the manufacturer's instructions, and place on ice:

1. Thaw the reagents at room temperature.
2. Spin down the reagent tubes for 5 seconds.
3. Ensure the reagents are fully mixed by performing 10 full volume pipette mixes.

Note: Do NOT vortex the Quick T4 DNA Ligase.

The NEBNext Quick Ligation Reaction Buffer (5x) may have a little precipitate. Allow the mixture to come to room temperature and pipette the buffer up and down several times to break up the precipitate, followed by vortexing the tube for several seconds to ensure the reagent is thoroughly mixed.

IMPORTANT

Do not vortex the Quick T4 DNA Ligase.

2 Spin down the Native Adapter (NA) and Quick T4 DNA Ligase, pipette mix and place on ice.

3 Thaw the Elution Buffer (EB) at room temperature and mix by vortexing. Then spin down and place on ice.

IMPORTANT

Depending on the wash buffer (LFB or SFB) used, the clean-up step after adapter ligation is designed to either enrich for DNA fragments of >3 kb, or purify all fragments equally.

- To enrich for DNA fragments of 3 kb or longer, use Long Fragment Buffer (LFB)
- To retain DNA fragments of all sizes, use Short Fragment Buffer (SFB)

4 Thaw either Long Fragment Buffer (LFB) or Short Fragment Buffer (SFB) at room temperature and mix by vortexing. Then spin down and place on ice.

5 In a 1.5 ml Eppendorf LoBind tube, mix in the following order:

Between each addition, pipette mix 10 - 20 times.

Reagent	Volume
Pooled barcoded sample	30 μ l
Native Adapter (NA)	5 μ l
NEBNext Quick Ligation Reaction Buffer (5X)	10 μ l
Quick T4 DNA Ligase	5 μ l
Total	50 μl

6 Thoroughly mix the reaction by gently pipetting and briefly spinning down.

7 Incubate the reaction for 20 minutes at room temperature.

IMPORTANT

The next clean-up step uses Long Fragment Buffer (LFB) or Short Fragment Buffer (SFB) rather than 80% ethanol to wash the beads. The use of ethanol will be detrimental to the sequencing reaction.

8 Resuspend the AMPure XP Beads (AXP) by vortexing.

9 Add 20 μ l of resuspended AMPure XP Beads (AXP) to the reaction and mix by pipetting.

10 Incubate on a Hula mixer (rotator mixer) for 10 minutes at room temperature.

11 Spin down the sample and pellet on the magnetic rack. Keep the tube on the magnet and pipette off the supernatant.

12 Wash the beads by adding either 125 μ l Long Fragment Buffer (LFB) or Short Fragment Buffer (SFB). Flick the beads to resuspend, spin down, then return the tube to the magnetic rack and allow the beads to pellet. Remove the supernatant using a pipette and discard.

13 Repeat the previous step.

14 Spin down and place the tube back on the magnet. Pipette off any residual supernatant.

15 Remove the tube from the magnetic rack and resuspend pellet in 15 μ l Elution Buffer (EB).

16 Spin down and incubate for 10 minutes at 37°C. Every 2 minutes, agitate the sample by gently flicking for 10 seconds to encourage DNA elution.

17 Pellet the beads on a magnet until the eluate is clear and colourless, for at least 1 minute.

18 Remove and retain 15 µl of eluate containing the DNA library into a clean 1.5 ml Eppendorf DNA LoBind tube.

Dispose of the pelleted beads

Quantify 1 µl of eluted sample using a Qubit fluorometer.

19 Depending on your required data output, prepare your final library as follows:

For **high output** of **simplex data**, prepare **35-50 fmol** of your final library to **12 µl** with Elution Buffer (EB).

For **duplex data**, prepare **10-20 fmol** of your final library to **12 µl** with Elution Buffer (EB).

Note: If the library yields are below the input recommendations, load the entire library.

IMPORTANT

We recommend loading the following amount of prepared library onto the R10.4.1 flow cell:

For **high output** of **simplex data**, load **35-50 fmol** of final library. This is to ensure high pore occupancy of >95% is reached. How to calculate pore occupancy can be found [here](#).

For **duplex data**, load **10-20 fmol** of final library. Loading more than 20 fmol of DNA can reduce the rate of duplex read capture.

END OF STEP

The prepared library is used for loading onto the flow cell. Store the library on ice until ready to load.

TIP

Library storage recommendations

We recommend storing libraries in Eppendorf DNA LoBind tubes at **4°C for short-term** storage or repeated use, for example, re-loading flow cells between washes.

For single use and **long-term storage** of more than 3 months, we recommend storing libraries at **-80°C** in Eppendorf DNA LoBind tubes.

Optional Action

If quantities allow, the library may be diluted in Elution Buffer (EB) for splitting across multiple flow cells.

Depending on how many flow cells the library will be split across, more Elution Buffer (EB) than what is supplied in the kit will be required.

Priming and loading the SpotON flow cell

~5 minutes

Materials

- Flow Cell Flush (FCF)
- Flow Cell Tether (FCT)
- Library Solution (LIS)
- Library Beads (LIB)
- Sequencing Buffer (SB)

Consumables

- 1.5 ml Eppendorf DNA LoBind tubes
- SpotON Flow Cell
- Nuclease-free water (e.g. ThermoFisher, cat # AM9937)
- (Optional) Bovine Serum Albumin (BSA) (50 mg/ml) (e.g. Invitrogen™ UltraPure™ BSA 50 mg/ml, AM2616)

Equipment

- MinION or GridION device
- MinION Flow Cell Light Shield
- P1000 pipette and tips
- P100 pipette and tips
- P20 pipette and tips
- P10 pipette and tips

IMPORTANT

Please note, this kit is only compatible with R10.4.1 flow cells (FLO-MIN114).

TIP

Priming and loading a flow cell

We recommend all new users watch the [Priming and loading your flow cell](#) video before your first run.

Using the Library Solution

We recommend using the Library Beads (LIB) for loading your library onto the flow cell for most sequencing experiments. However, if you have previously used water to load your library, you must use Library Solution (LIS) instead of water.

Note: Some customers have noticed that viscous libraries can be loaded more easily when not using Library Beads (LIB).

- 1 **Thaw the Sequencing Buffer (SB), Library Beads (LIB) or Library Solution (LIS, if using), Flow Cell Tether (FCT) and one tube of Flow Cell Flush (FCF) at room temperature before mixing by vortexing. Then spin down and store on ice.**

IMPORTANT

For optimal sequencing performance and improved output on MinION R10.4.1 flow cells (FLO-MIN114), we recommend adding Bovine Serum Albumin (BSA) to the flow cell priming mix at a final concentration of 0.2 mg/ml.

Note: We do not recommend using any other albumin type (e.g. recombinant human serum albumin).

2 To prepare the flow cell priming mix with BSA, combine Flow Cell Flush (FCF) and Flow Cell Tether (FCT), as directed below. Mix by pipetting at room temperature.

Note: We are in the process of reformatting our kits with single-use tubes into a bottle format. Please follow the instructions for your kit format.

Single-use tubes format:

Add 5 µl Bovine Serum Albumin (BSA) at 50 mg/ml and 30 µl Flow Cell Tether (FCT) directly to a tube of Flow Cell Flush (FCF).

Bottle format:

In a suitable tube for the number of flow cells, combine the following reagents:

Reagent	Volume per flow cell
Flow Cell Flush (FCF)	1,170 µl
Bovine Serum Albumin (BSA) at 50 mg/ml	5 µl
Flow Cell Tether (FCT)	30 µl
Total volume	1,205 µl

3 Open the MinION or GridION device lid and slide the flow cell under the clip. Press down firmly on the flow cell to ensure correct thermal and electrical contact.

1a
Insert the flow cell into the device under the clip and press down firmly.

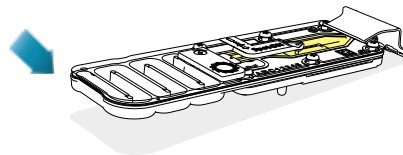

Key:
● Storage buffer
● Priming mix
● DNA library

1b
Insert the flow cell into the device under the clip and press down firmly.

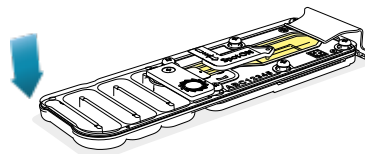

Optional Action

Complete a flow cell check to assess the number of pores available before loading the library.

This step can be omitted if the flow cell has been checked previously.

See the [flow cell check instructions](#) in the MinKNOW protocol for more information.

4 Slide the flow cell priming port cover clockwise to open the priming port.

IMPORTANT

Take care when drawing back buffer from the flow cell. Do not remove more than 20-30 μl , and make sure that the array of pores are covered by buffer at all times. Introducing air bubbles into the array can irreversibly damage pores.

5 After opening the priming port, check for a small air bubble under the cover. Draw back a small volume to remove any bubbles:

1. Set a P1000 pipette to 200 μl
2. Insert the tip into the priming port
3. Turn the wheel until the dial shows 220-230 μl , to draw back 20-30 μl , or until you can see a small volume of buffer entering the pipette tip

Note: Visually check that there is continuous buffer from the priming port across the sensor array.

3 Insert a P1000 pipette with an empty tip into the **Priming port**. Turn the pipette wheel to draw back 20-30 μl or until you can see a small volume of buffer entering the pipette tip.

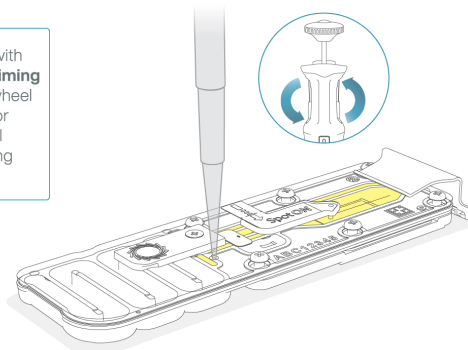

- 6 Load 800 µl of the priming mix into the flow cell via the priming port, avoiding the introduction of air bubbles. Wait for five minutes. During this time, prepare the library for loading by following the steps below.

4 Slowly load 800 µl of the priming mix into the **Priming port**. Ensure there are no air bubbles in the pipette tip.

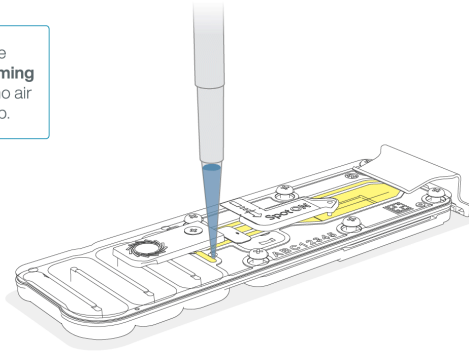

Wait 5 minutes before proceeding to the next step.

- 7 Thoroughly mix the contents of the Library Beads (LIB) by pipetting.

IMPORTANT

The Library Beads (LIB) tube contains a suspension of beads. These beads settle very quickly. It is vital that they are mixed immediately before use.

- 8 In a new 1.5 ml Eppendorf DNA LoBind tube, prepare the library for loading as follows:

Reagent	Volume per flow cell
Sequencing Buffer (SB)	37.5 µl
Library Beads (LIB) mixed immediately before use, or Library Solution (LIS), if using	25.5 µl
DNA library	12 µl
Total	75 µl

9 Complete the flow cell priming:

1. Gently lift the SpotON sample port cover to make the SpotON sample port accessible.
2. Load **200 μl** of the priming mix into the flow cell priming port (**not** the SpotON sample port), avoiding the introduction of air bubbles.

5 Gently flip open SpotON sample port cover.

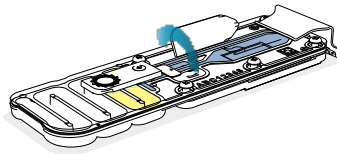

6 Load 200 μl of the priming mix into the **Priming Port**. Ensure there are no air bubbles in the pipette tip.

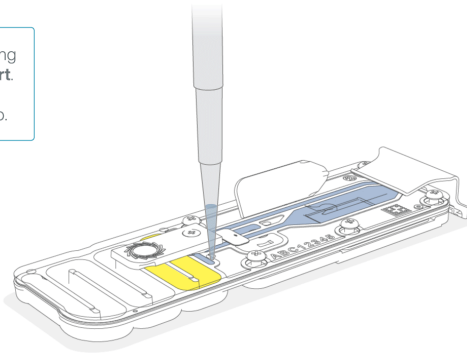

10 Mix the prepared library gently by pipetting up and down just prior to loading.

11 Add 75 μ l of the prepared library to the flow cell via the SpotON sample port in a dropwise fashion. Ensure each drop flows into the port before adding the next.

7 Pipette mix the prepared library and load 75 μ l dropwise into the **SpotON** sample port, ensuring each drop flows into the port.

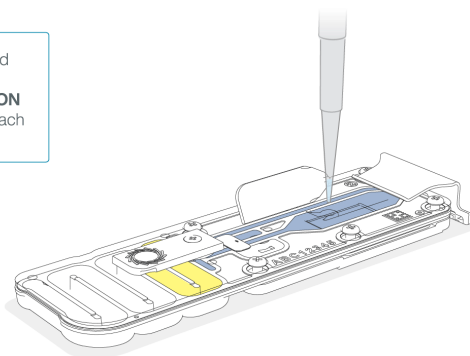

12 Gently replace the SpotON sample port cover, making sure the bung enters the SpotON port and close the priming port.

8

Gently replace the **SpotON** sample port cover.

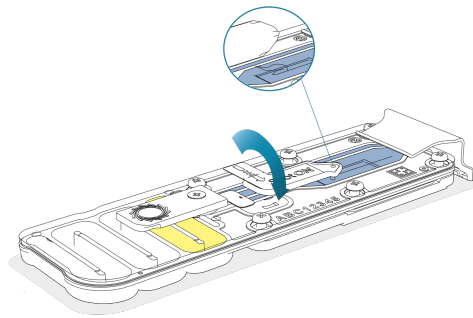

9

Gently close the **Priming port**.

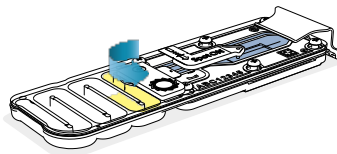

IMPORTANT

Install the light shield on your flow cell as soon as library has been loaded for optimal sequencing output.

We recommend leaving the light shield on the flow cell when library is loaded, including during any washing and reloading steps. The shield can be removed when the library has been removed from the flow cell.

13 Place the light shield onto the flow cell, as follows:

1. Carefully place the leading edge of the light shield against the clip.

Note: Do not force the light shield underneath the clip.

2. Gently lower the light shield onto the flow cell. The light shield should sit around the SpotON cover, covering the entire top section of the flow cell.

10

Carefully align the **light shield** against the clip and lower onto the flow cell.

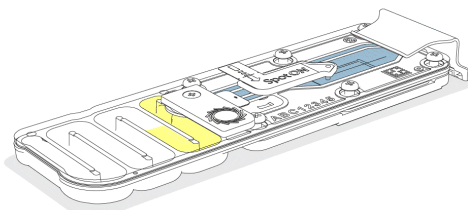

CAUTION

The MinION Flow Cell Light Shield is not secured to the flow cell and careful handling is required after installation.

END OF STEP

Close the device lid and set up a sequencing run on MinKNOW.

Data acquisition and basecalling

Overview of nanopore data analysis

For a full overview of nanopore data analysis, which includes options for basecalling and post-basecalling analysis, please refer to the [Data Analysis](#) document.

How to start sequencing

The sequencing device control, data acquisition and real-time basecalling are carried out by the MinKNOW software. It is assumed you have already installed MinKNOW on your computer. There are multiple options for how to carry out sequencing:

1. Data acquisition and basecalling in real-time using MinKNOW on a computer

Follow the instructions in the [MinKNOW protocol](#) beginning from the "Starting a sequencing run" section until the end of the "Completing a MinKNOW run" section.

2. Data acquisition and basecalling in real-time using the GridION device

Follow the instructions in the [GridION user manual](#).

3. Data acquisition and basecalling in real-time using the MinION Mk1C device

Follow the instructions in the [MinION Mk1C user manual](#).

4. Data acquisition and basecalling in real-time using the PromethION device

Follow the instructions in the [PromethION user manual](#) or the [PromethION 2 Solo user manual](#).

5. Data acquisition using MinKNOW on a computer and basecalling at a later time using MinKNOW

Follow the instructions in the [MinKNOW protocol](#) beginning from the "Starting a sequencing run" section until the end of the "Completing a MinKNOW run" section. **When setting your experiment parameters, set the *Basecalling* tab to OFF.** After the sequencing experiment has completed, follow the instructions in the [Post-run analysis](#) section of the [MinKNOW protocol](#).

Downstream analysis

Post-basecalling analysis

There are several options for further analysing your basecalled data:

1. EPI2ME platform

The EPI2ME platform is a cloud-based data analysis service developed by Metrichor Ltd., a subsidiary of Oxford Nanopore Technologies. The EPI2ME platform offers a range of analysis workflows, e.g. for metagenomic identification, barcoding, alignment, and structural variant calling. The analysis requires no additional equipment or compute power, and provides an easy-to-interpret report with the results. For instructions on how to run an analysis workflow in EPI2ME, please follow the instructions in the [EPI2ME protocol](#), beginning at the "Starting data analysis" step.

2. EPI2ME Labs tutorials and workflows

For more in-depth data analysis, Oxford Nanopore Technologies offers a range of bioinformatics tutorials and workflows available in EPI2ME Labs, which are available in the [EPI2ME Labs](#) section of the Community. The platform provides a vehicle where workflows deposited in GitHub by our Research and Applications teams can be showcased with descriptive texts, functional bioinformatics code and example data.

3. Research analysis tools

Oxford Nanopore Technologies' Research division has created a number of analysis tools, which are available in the [Oxford Nanopore GitHub repository](#). The tools are aimed at advanced users, and contain instructions for how to install and run the software. They are provided as-is, with minimal support.

4. Community-developed analysis tools

If a data analysis method for your research question is not provided in any of the resources above, please refer to the [Bioinformatics section of the Resource centre](#). Numerous members of the Nanopore Community have developed their own tools and pipelines for analysing nanopore sequencing data, most of which are available on GitHub. Please be aware that these tools are not supported by Oxford Nanopore Technologies, and are not guaranteed to be compatible with the latest chemistry/software configuration.

Ending the experiment

Materials

- Flow Cell Wash Kit (EXP-WSH004)

- 1 **After your sequencing experiment is complete, if you would like to reuse the flow cell, please follow the Flow Cell Wash Kit protocol and store the washed flow cell at 2-8°C.**

The [Flow Cell Wash Kit protocol](#) is available on the Nanopore Community.

TIP

We recommend you to wash the flow cell as soon as possible after you stop the run. However, if this is not possible, leave the flow cell on the device and wash it the next day.

- 2 **Alternatively, follow the returns procedure to flush out the flow cell ready to send back to Oxford Nanopore.**

Instructions for returning flow cells can be found [here](#).

Note: All flow cells must be flushed with deionised water before returning the product.

IMPORTANT

If you encounter issues or have questions about your sequencing experiment, please refer to the [Troubleshooting Guide](#) that can be found in the online version of this protocol.

Data acquisition and duplex basecalling

Overview of nanopore data analysis

For a full overview of nanopore data analysis, which includes options for basecalling and post-basecalling analysis, please refer to the [Data Analysis](#) document.

Duplex basecalling

Kit 14 chemistry has improved duplex basecalling which requires rebasecalling on [Dorado](#) after simplex basecalling has been performed on MinKNOW.

For detailed information on setting up your sequencing run, for both simplex and duplex basecalling, please see the [Kit 14 sequencing and duplex basecalling info sheet](#).

Note: When running Dorado, we recommend stopping other basecalling for the best performance by maximising memory available to Dorado. This can be stopped and restarted when Dorado has finished via the GUI on MinKNOW.

Below explains the sequencing options available on MinKNOW.

How to start sequencing

The sequencing device control, data acquisition and real-time basecalling are carried out by the MinKNOW software. It is assumed you have already installed MinKNOW on your computer. There are multiple options for how to carry out sequencing:

1. Data acquisition and basecalling in real-time using MinKNOW on a computer

Follow the instructions in the [MinKNOW protocol](#) beginning from the "Starting a sequencing run" section until the end of the "Completing a MinKNOW run" section.

2. Data acquisition and basecalling in real-time using the GridION device

Follow the instructions in the [GridION user manual](#).

3. Data acquisition and basecalling in real-time using the MinION Mk1C device

Follow the instructions in the [MinION Mk1C user manual](#).

4. Data acquisition and basecalling in real-time using the PromethION device

Follow the instructions in the [PromethION user manual](#) or the [PromethION 2 Solo user manual](#).

5. Data acquisition using MinKNOW on a computer and basecalling at a later time using MinKNOW

Follow the instructions in the [MinKNOW protocol](#) beginning from the "Starting a sequencing run" section until the end of the "Completing a MinKNOW run" section. **When setting your experiment parameters, set the *Basecalling* tab to OFF.** After the sequencing experiment has completed, follow the instructions in the [Post-run analysis](#) section of the [MinKNOW protocol](#).

Downstream analysis

Post-basecalling analysis

There are several options for further analysing your basecalled data:

1. EPI2ME platform

The EPI2ME platform is a cloud-based data analysis service developed by Metrichor Ltd., a subsidiary of Oxford Nanopore Technologies. The EPI2ME platform offers a range of analysis workflows, e.g. for metagenomic identification, barcoding, alignment, and structural variant calling. The analysis requires no additional equipment or compute power, and provides an easy-to-interpret report with the results. For instructions on how to run an analysis workflow in EPI2ME, please follow the instructions in the [EPI2ME protocol](#), beginning at the "Starting data analysis" step.

2. EPI2ME Labs tutorials and workflows

For more in-depth data analysis, Oxford Nanopore Technologies offers a range of bioinformatics tutorials and workflows available in EPI2ME Labs, which are available in the [EPI2ME Labs](#) section of the Community. The platform provides a vehicle where workflows deposited in GitHub by our Research and Applications teams can be showcased with descriptive texts, functional bioinformatics code and example data.

3. Research analysis tools

Oxford Nanopore Technologies' Research division has created a number of analysis tools, which are available in the Oxford Nanopore [GitHub repository](#). The tools are aimed at advanced users, and contain instructions for how to install and run the software. They are provided as-is, with minimal support.

4. Community-developed analysis tools

If a data analysis method for your research question is not provided in any of the resources above, please refer to the [Bioinformatics section of the Resource centre](#). Numerous members of the Nanopore Community have developed their own tools and pipelines for analysing nanopore sequencing data, most of which are available on GitHub. Please be aware that these tools are not supported by Oxford Nanopore Technologies, and are not guaranteed to be compatible with the latest chemistry/software configuration.

Ending the experiment

Materials

- Flow Cell Wash Kit (EXP-WSH004)

- 1 **After your sequencing experiment is complete, if you would like to reuse the flow cell, please follow the Flow Cell Wash Kit protocol and store the washed flow cell at 2-8°C.**

The [Flow Cell Wash Kit protocol](#) is available on the Nanopore Community.

TIP

We recommend you to wash the flow cell as soon as possible after you stop the run. However, if this is not possible, leave the flow cell on the device and wash it the next day.

- 2 **Alternatively, follow the returns procedure to flush out the flow cell ready to send back to Oxford Nanopore.**

Instructions for returning flow cells can be found [here](#).

Note: All flow cells must be flushed with deionised water before returning the product.

IMPORTANT

If you encounter issues or have questions about your sequencing experiment, please refer to the Troubleshooting Guide that can be found in the online version of this protocol.

Issues during DNA/RNA extraction and library preparation for Kit 14

Below is a list of the most commonly encountered issues, with some suggested causes and solutions.

We also have an FAQ section available on the [Nanopore Community Support](#) section.

If you have tried our suggested solutions and the issue still persists, please contact Technical Support via email (support@nanoporetech.com) or via [LiveChat](#) in the Nanopore Community.

Low sample quality

Observation	Possible cause	Comments and actions
Low DNA purity (Nanodrop reading for DNA OD 260/280 is <1.8 and OD 260/230 is <2.0-2.2)	The DNA extraction method does not provide the required purity	The effects of contaminants are shown in the Contaminants document. Please try an alternative extraction method that does not result in contaminant carryover. Consider performing an additional SPRI clean-up step.
Low RNA integrity (RNA integrity number <9.5 RIN, or the rRNA band is shown as a smear on the gel)	The RNA degraded during extraction	Try a different RNA extraction method . For more info on RIN, please see the RNA Integrity Number document. Further information can be found in the DNA/RNA Handling page.
RNA has a shorter than expected fragment length	The RNA degraded during extraction	Try a different RNA extraction method . For more info on RIN, please see the RNA Integrity Number document. Further information can be found in the DNA/RNA Handling page. We recommend working in an RNase-free environment, and to keep your lab equipment RNase-free when working with RNA.

Low DNA recovery after AMPure bead clean-up

Observation	Possible cause	Comments and actions
Low recovery	DNA loss due to a lower than intended AMPure beads-to-sample ratio	<ol style="list-style-type: none">1. AMPure beads settle quickly, so ensure they are well resuspended before adding them to the sample.2. When the AMPure beads-to-sample ratio is lower than 0.4:1, DNA fragments of any size will be lost during the clean-up.

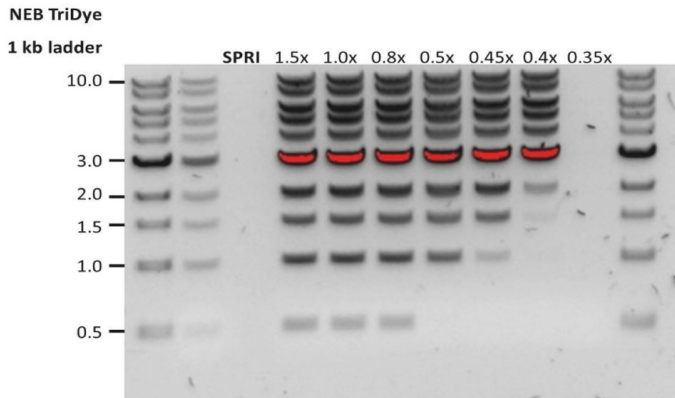
Observation	Possible cause	Comments and actions
Low recovery	DNA fragments are shorter than expected	<p>The lower the AMPure beads-to-sample ratio, the more stringent the selection against short fragments. Please always determine the input DNA length on an agarose gel (or other gel electrophoresis methods) and then calculate the appropriate amount of AMPure beads to use.</p> 
Low recovery after end-prep	The wash step used ethanol <70%	DNA will be eluted from the beads when using ethanol <70%. Make sure to use the correct percentage.

Issues during the sequencing run for Kit 14

Below is a list of the most commonly encountered issues, with some suggested causes and solutions.

We also have an FAQ section available on the [Nanopore Community Support](#) section.

If you have tried our suggested solutions and the issue still persists, please contact Technical Support via email (support@nanoporetech.com) or via [LiveChat](#) in the Nanopore Community.

Fewer pores at the start of sequencing than after Flow Cell Check

Observation	Possible cause	Comments and actions
MinKNOW reported a lower number of pores at the start of sequencing than the number reported by the Flow Cell Check	An air bubble was introduced into the nanopore array	After the Flow Cell Check it is essential to remove any air bubbles near the priming port before priming the flow cell. If not removed, the air bubble can travel to the nanopore array and irreversibly damage the nanopores that have been exposed to air. The best practice to prevent this from happening is demonstrated in this video .

Observation	Possible cause	Comments and actions
MinKNOW reported a lower number of pores at the start of sequencing than the number reported by the Flow Cell Check	The flow cell is not correctly inserted into the device	Stop the sequencing run, remove the flow cell from the sequencing device and insert it again, checking that the flow cell is firmly seated in the device and that it has reached the target temperature. If applicable, try a different position on the device (GridION/PromethION).
MinKNOW reported a lower number of pores at the start of sequencing than the number reported by the Flow Cell Check	Contaminations in the library damaged or blocked the pores	The pore count during the Flow Cell Check is performed using the QC DNA molecules present in the flow cell storage buffer. At the start of sequencing, the library itself is used to estimate the number of active pores. Because of this, variability of about 10% in the number of pores is expected. A significantly lower pore count reported at the start of sequencing can be due to contaminants in the library that have damaged the membranes or blocked the pores. Alternative DNA/RNA extraction or purification methods may be needed to improve the purity of the input material. The effects of contaminants are shown in the Contaminants Know-how piece . Please try an alternative extraction method that does not result in contaminant carryover.

MinKNOW script failed

Observation	Possible cause	Comments and actions
MinKNOW shows "Script failed"		Restart the computer and then restart MinKNOW. If the issue persists, please collect the MinKNOW log files and contact Technical Support. If you do not have another sequencing device available, we recommend storing the flow cell and the loaded library at 4°C and contact Technical Support for further storage guidance.

Pore occupancy below 40%

Observation	Possible cause	Comments and actions
Pore occupancy <40%	Not enough library was loaded on the flow cell	10–20 fmol of good quality library can be loaded on to a MinION/GridION flow cell. Please quantify the library before loading and calculate mols using tools like the Promega Biomath Calculator , choosing "dsDNA: µg to pmol"
Pore occupancy close to 0	The Native Barcoding Kit was used, and ethanol was used instead of LFB or SFB at the wash step after sequencing adapter ligation	Ethanol can denature the motor protein on the sequencing adapters. Make sure the LFB or SFB buffer was used after ligation of sequencing adapters.
Pore occupancy close to 0	No tether on the flow cell	Tethers are added during flow cell priming (FCT tube). Make sure FCT was added to FCF before priming.

Shorter than expected read length

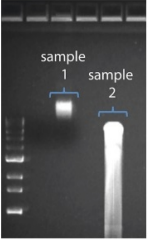
Observation	Possible cause	Comments and actions
Shorter than expected read length	Unwanted fragmentation of DNA sample	<p>Read length reflects input DNA fragment length. Input DNA can be fragmented during extraction and library prep.</p> <ol style="list-style-type: none"> 1. Please review the Extraction Methods in the Nanopore Community for best practice for extraction. 2. Visualise the input DNA fragment length distribution on an agarose gel before proceeding to the library prep.  <p>In the image above, Sample 1 is of high molecular weight, whereas Sample 2 has been fragmented.</p> <ol style="list-style-type: none"> 3. During library prep, avoid pipetting and vortexing when mixing reagents. Flicking or inverting the tube is sufficient.

Large proportion of unavailable pores

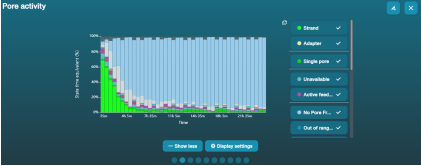
Observation	Possible cause	Comments and actions
<p>Large proportion of unavailable pores (shown as blue in the channels panel and pore activity plot)</p>  <p>The pore activity plot above shows an increasing proportion of "unavailable" pores over time.</p>	Contaminants are present in the sample	<p>Some contaminants can be cleared from the pores by the unblocking function built into MinKNOW. If this is successful, the pore status will change to "sequencing pore". If the portion of unavailable pores stays large or increases:</p> <ol style="list-style-type: none"> 1. A nuclease flush using the Flow Cell Wash Kit (EXP-WSH004) can be performed, or 2. Run several cycles of PCR to try and dilute any contaminants that may be causing problems.

Large proportion of inactive pores

Observation	Possible cause	Comments and actions
Large proportion of inactive/unavailable pores (shown as light blue in the channels panel and pore activity plot. Pores or membranes are irreversibly damaged)	Air bubbles have been introduced into the flow cell	Air bubbles introduced through flow cell priming and library loading can irreversibly damage the pores. Watch the Priming and loading your flow cell video for best practice

Observation	Possible cause	Comments and actions
Large proportion of inactive/unavailable pores	Certain compounds co-purified with DNA	Known compounds, include polysaccharides, typically associate with plant genomic DNA. 1. Please refer to the Plant leaf DNA extraction method . 2. Clean-up using the QIAGEN PowerClean Pro kit. 3. Perform a whole genome amplification with the original gDNA sample using the QIAGEN REPLI-g kit.
Large proportion of inactive/unavailable pores	Contaminants are present in the sample	The effects of contaminants are shown in the Contaminants Know-how piece. Please try an alternative extraction method that does not result in contaminant carryover.

Reduction in sequencing speed and q-score later into the run

Observation	Possible cause	Comments and actions
Reduction in sequencing speed and q-score later into the run	Fast fuel consumption is typically seen in Kit 9 chemistry (e.g. SQK-LSK109) when the flow cell is overloaded with library. Please see the appropriate protocol for your DNA library to find the recommendation.	Add more fuel to the flow cell by following the instructions in the MinKNOW protocol . In future experiments, load lower amounts of library to the flow cell.

Temperature fluctuation

Observation	Possible cause	Comments and actions
Temperature fluctuation	The flow cell has lost contact with the device	Check that there is a heat pad covering the metal plate on the back of the flow cell. Re-insert the flow cell and press it down to make sure the connector pins are firmly in contact with the device. If the problem persists, please contact Technical Services.

Failed to reach target temperature

Observation	Possible cause	Comments and actions
MinKNOW shows "Failed to reach target temperature"	The instrument was placed in a location that is colder than normal room temperature, or a location with poor ventilation (which leads to the flow cells overheating)	MinKNOW has a default timeframe for the flow cell to reach the target temperature. Once the timeframe is exceeded, an error message will appear and the sequencing experiment will continue. However, sequencing at an incorrect temperature may lead to a decrease in throughput and lower q-scores. Please adjust the location of the sequencing device to ensure that it is placed at room temperature with good ventilation, then re-start the process in MinKNOW. Please refer to this FAQ for more information on MinION Mk 1B temperature control.